

PSR-500

Compact, high-resolution frequency-modulated continuous-wave (FMCW) radar capable of detecting and tracking a pedestrian up to 500 m away.

- All weather detection (day/night, rain, fog, snow...)
- Detection on 20 hectares
- Surface detection
- Adaptable to land / air / sea
- Tracking
- Easy to connect



PERFORMANCE

DETECTION RANGE	Pedestrian up to 500 m Vehicle up to 500 m
COVER	90° horizontal 35° vertical
ANGULAR ACCURACY	Pedestrians < 2° à 500 m
RESOLUTION IN DISTANCE	1.50 m



SPEED DETECTED LAND AND WATER FOR AN RESA* = 1 M²	0,1 to 30 m / s 0 to 30 kts
REFRESH	3 Hz (333 ms)
NUMBER OF SIMULTANEOUS TARGETS	50

OPERATIONAL FEATURES

FRÉQUENCY	Band C - 5,8 GHz
WAVEFORM	FMCW
RADIATED POWER	25 mW
APPLICATION FOR AUTHORIZATION TO BROADCAST	No

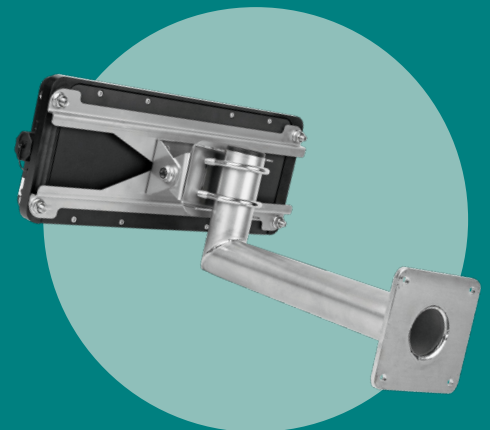

TECHNICAL FEATURES

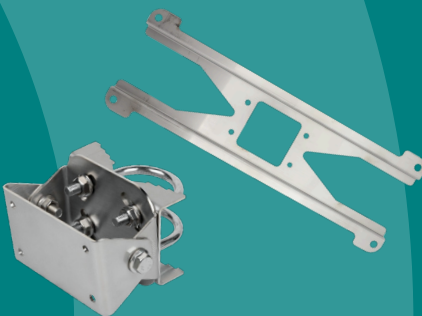

Hanging mechanism



Cables :
122-1119-001
+ 122-1121-001
+ 122+1117-001

DIMENSIONS (W X H X D)	PSR-500 : 370 x 150 x 50 mm PSB-500 : 300 x 185 x 90 mm
WEIGHT	1,8 kg for the PSR-500 3 kg for the PSB-500
DATA PROCESSING UNIT	Inclus dans la PSB
CONNECTION INTERFACE	RJ45 ou FO 1000 LX mono IP67 ou FO 1000 SX mono IP67
POWER SUPPLY	PSB-500 : 48V DC PSR-500 : RJ45 POE via la PSB-500
CONSUMPTION	50 Wh
IK AND IP INDEX	IK08 – IP67
CE MARKING	YES
OPERATING TEMPERATURE	- 20 / + 60 °C

Interfaces with Sentinis,
software suite and Nomad solutions
<https> and 802.1x compatible

*RESA: Radar Equivalent Surface Area

EPSI © ITNI S.A.S. All rights reserved. Exclusive and confidential ITNI.
Reproduction in whole or in part is prohibited without prior written consent..

